



FRC 704, SGP Warriors

Exercise 1: Introduction to LabVIEW for FRC

Originally by

Introduction:

This tutorial demonstrates how to get the cRIO-FRC up and running a motor. It walks through the hardware setup and the programming necessary to control a motor with a joystick, as well as basics such as setting up the FRC Control System, necessary network configuration, and setting up an FRC Robot Project.

Goal:

In the following exercise, you will build a VI that will add or subtract two numbers, depending on the user specification, and display the result. This exercise requires the following hardware:

FRC cRIO and the five included modules

Driver Station

Motor

Jaguar motor controller

Digital Side Car

12 V battery

SH37 68 pin cable

Power Distribution Board

Two Ethernet Cables

14 gauge wire

USB Joystick

NOTE: The robot should be in the basic configuration

Implementation:

- 1) Launch LabVIEW
 - Go to **Start>>Programs>>National Instruments LabVIEW 8.6.**
- 2) Create a New FRC cRIO Robot Project

In the **Getting Started** Window, under **New**, select **FRC cRIO Robot Project**.

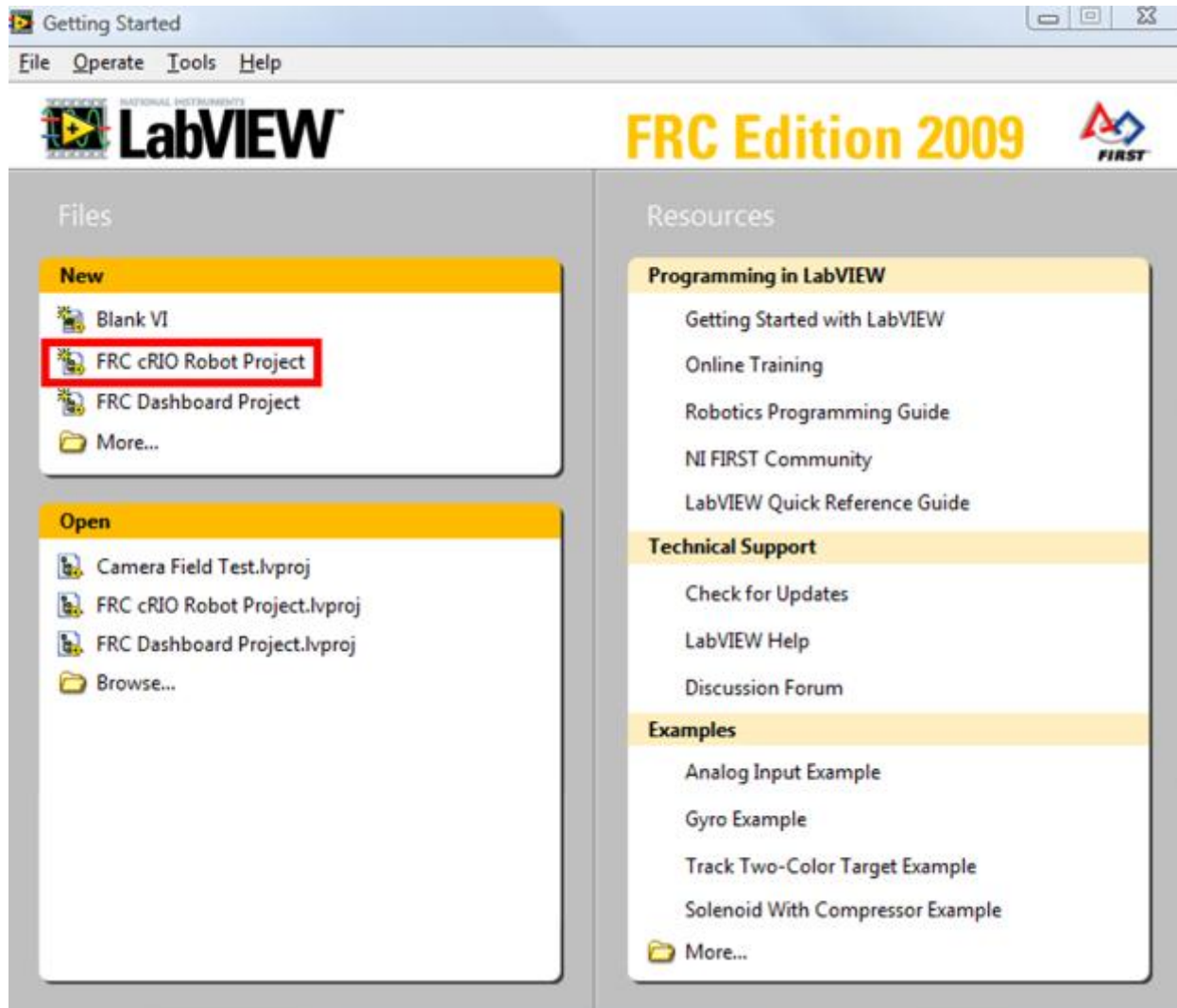

Name the project, set the save path, enter the cRIO-FRC's IP address (10.0\xx.yy.2), and select **FRC cRIO Robot Project**. The IP address is 10.xx.yy.2 where xx is the first 2 digits of the team number and the yy is the second 2 digits of the team number. Once you're done, click **Finish**.

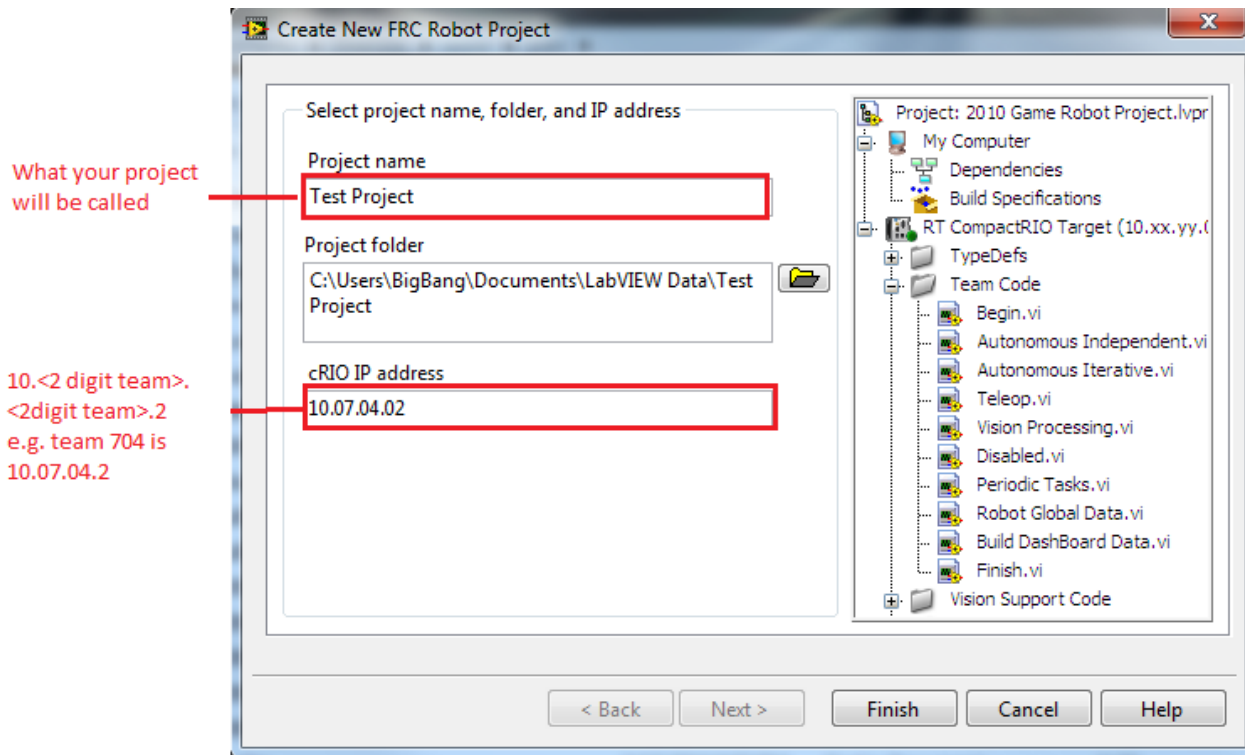

3) Add a VI to the Real-Time Controller

In the project window, right-click on **RT CompactRIO Target (10.07.04.2)** and select **New»VI**.

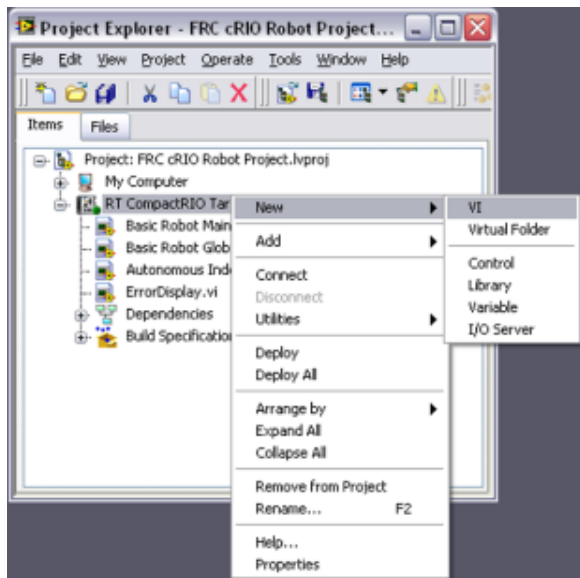

- Save the new VI as *Simple Motor Control*. Notice that LabVIEW places the new VI inside the cRIO target tree, which means the VI will run on the cRIO

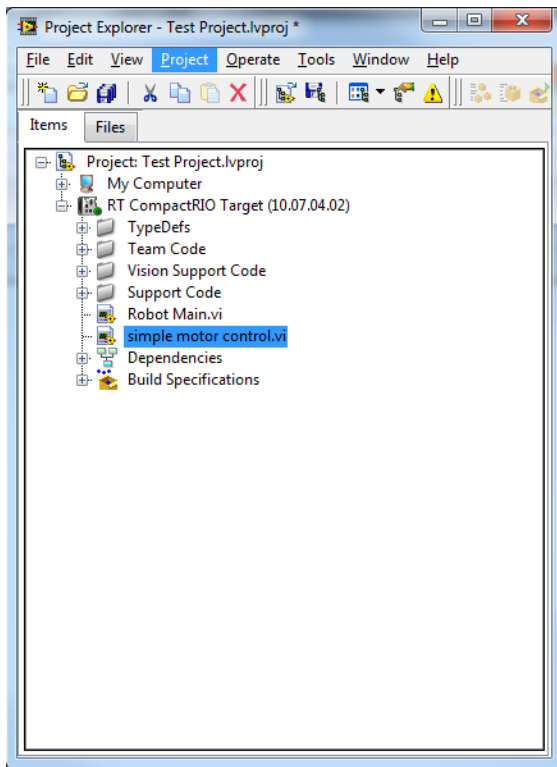

4) Write the Program for Motor Control

- Go to the block diagram of *Simple Motor Control* by selecting **Window»Show Block Diagram**.
- Create a while loop by right-clicking anywhere in the white space on the block diagram and selecting **Programming»Structures»While Loop**.
- Click, drag, and release on the block diagram to specify the size of the while loop.
- Right-click the **conditional terminal** in the bottom right corner of the while loop and select **create control**. Notice that a Stop button appears on the front panel.



The while loop allows all code inside of it to run continuously until a condition is met.

- Now right-click in the white space of the block diagram outside of the while loop and navigate to the **WPI Robotics Library»RobotDrive»Advanced»Motor Control** palette and place the **Open VI** on the block diagram to the left of the while loop.

***NOTE:** If you're having trouble finding a Vi, hit <ctrl> <space> and type in "motor" and all Vi's with "motor" in the name will be shown. Also, the first time <ctrl><space> is hit, it will take a minute before it comes up.

- Leave **Jaguar** as the motor type
- Hover your mouse on the left side of the **Open VI** and notice the different inputs. Right-click on the DIO Module input of the **Open VI** and select **Create » Constant** to place a constant on the Block Diagram. Click inside the constant to select **Slot 4**. (This selects the digital module (9403) in the fourth slot of the cRIO.)

***NOTE:** You can see details of a Vi's inputs and outputs and other help by hitting **Control-H**.

- Right-click on the **PWM Channel** input of the **Open VI** and select **Create » Constant**. Set the value of this constant to **PWM 1**. This selects the PWM channel that our motor controller is connected to.

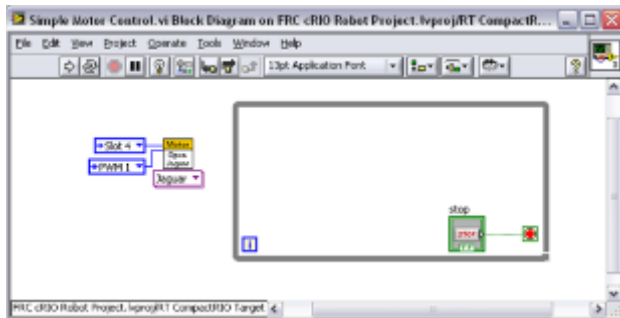

- Place the **Set Speed VI** from **WPI Robotics Library»RobotDrive»Advanced»Motor Control** in the middle of the while loop.
- Wire the **MotorControlDevRef** and **error** terminals out of the right side of the Open VI to the inputs on the left side of the **Set Speed VI**.
- Right-click the **speed** input of the **Set Speed VI** and select **Create»Control**. (This creates a control on the front panel that allows us to specify the speed of the motor. Because we have the **Set Speed VI** in a while loop, we can change the motor speed from the front panel while the motor is running. This VI will continue to run until your push the stop button.)

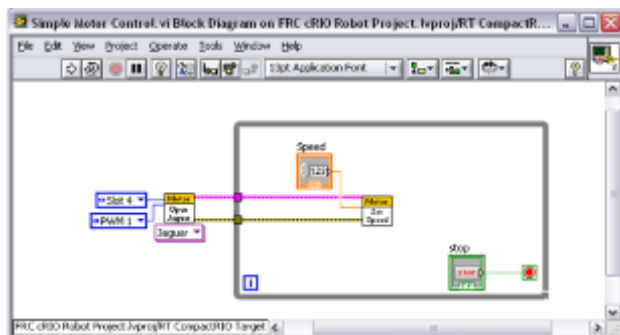

- Place the **Close VI** from **WPI Robotics Library»RobotDrive»Advanced»Motor Control** palette to the right of the while loop.
- Wire the **reference** and **error** outputs of the Set Speed VI to the inputs of the Close VI.

- Place the **Start Communication.vi** from **WPI Robotics Library»Driver Station** on the left side of the while loop.
- Place the **Stop Communication.vi** from **Robotics Library»Driver Station** to the right of the while loop.
- Branch the green wire from the stop button created earlier to the input of the **Stop Communication VI**.

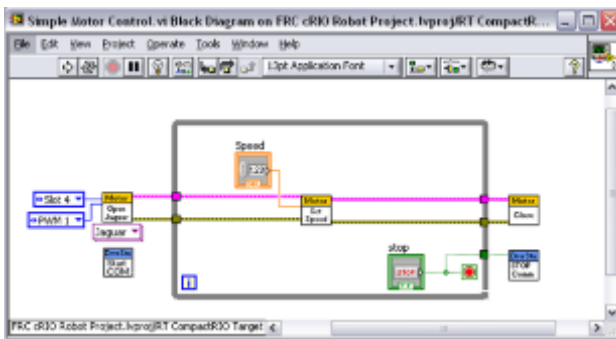

These VIs are necessary to establish a connection with the cRIO when the program starts and to close that connection when the program stops.

- Place the Watchdog **Open**, **Set Enabled**, and **Close** VIs located at **WPI Robotics Library»Utilities»Watchdog** on the block diagram as shown in the figure below.
- Right-click on the **enable watchdog** input and select **Create » Constant**. Set the value of the constant to **False**. This disables the optional user watchdog.
- You will also need to add a time delay of 10 ms to the while loop. To do this, bring up the functions palette and select **Programming » Timing » Wait (ms)**.

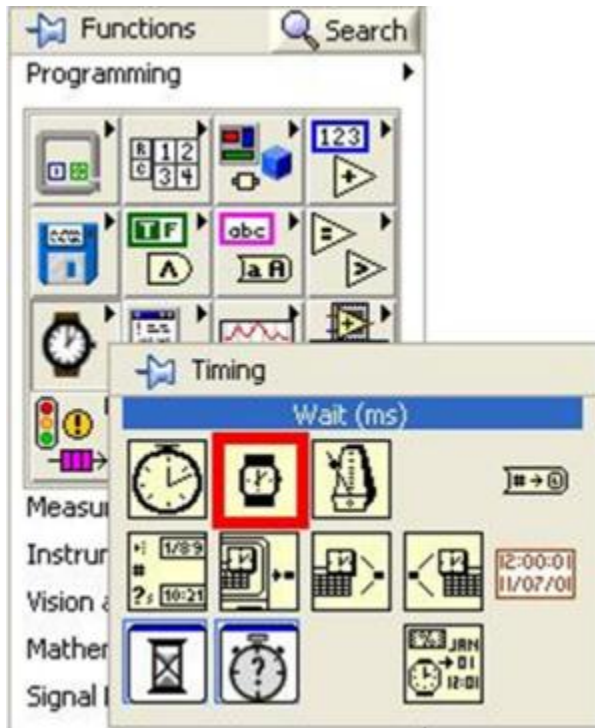

- Place the **Wait** function on the block diagram. Right-click on the **milliseconds to wait** input and select **Create » Constant**. Set the value of the constant to 10. This wait statement causes the VI to allow other processes on your cRIO to execute. Without this statement, your program will use 100% of the processor resources.

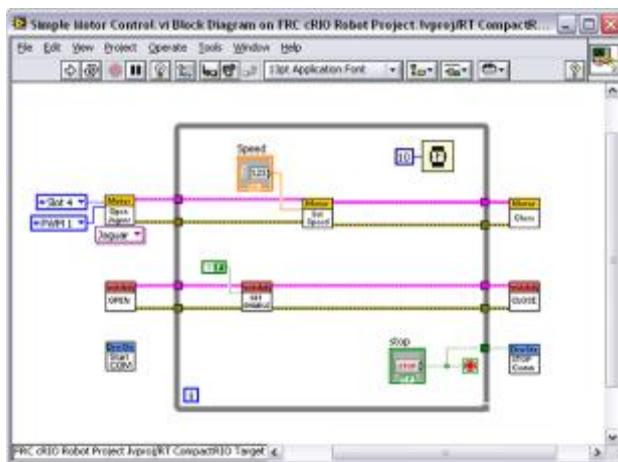

- 5) Save and Run the VI
 - Go to the front panel by hitting **Control-E**.
 - Save the VI.
 - Click the run button, the white arrow at the top, to download the code to the cRIO.

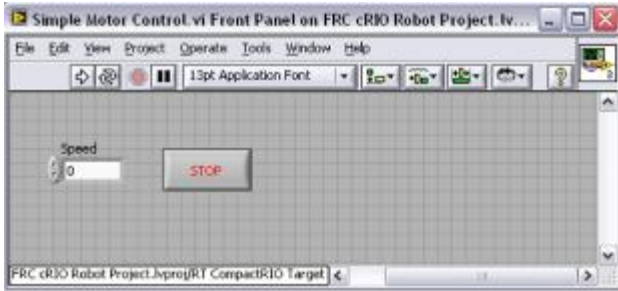

- Once the program has finished downloading, try changing the value of the speed control from 0 to 0.1 by clicking inside the control and typing the value. The motor should now start moving slowly.
 - Keep increasing this number up to 1, at which point the motor will spin at full speed.
 - Notice that inputting negative values for speed will spin the motor in the opposite direction.
 - Press the stop button on the front panel to stop the program.
- 6) Add a Joystick to Control the Motors
- Make sure the joystick is plugged into USB port 1 of the driver station.
 - Go back to the block diagram.
 - Place the joystick **Open VI** located at **WPI Robotics Library»Driver Station»Joystick** to the left of the while loop.
 - Right-click on the joystick device input and select **Create » Constant**.
 - Click on the constant and select **USB 1**. (This selects the joystick located at driver station USB port 1.)
 - Place the **Get Axis VI** from **WPI Robotics Library»Driver Station»Joystick** inside the while loop.
 - Connect the **JoystickDevRef** output of the joystick **Open VI** to the **reference** input of the **Get Axis VI**.
 - Right-click on the **Axis** input of the Get Axis VI and select **Create » Constant**.
 - Click on the constant and select **Axis 2**. (On this joystick, axis 2 is the forward/backward axis)
 - Delete the speed control made earlier by clicking the control and hitting the delete key on the keyboard.

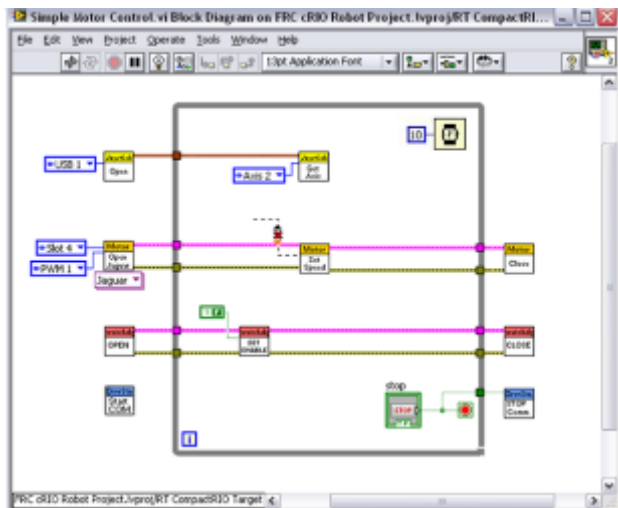

On your own:

Try adding a 2nd motor to PWM 2 and control it from another axis of the Joystick

Note that this has been tested but it still may not be perfect. Have fun and happy learning.